

CITY OF BALLWIN, MISSOURI  
NOTICE TO CONTRACTORS

The City of Ballwin seeks bids from qualified contractors to modernize the restrooms at the Ballwin Golf Course Event Center, 333 Holloway Road, Ballwin, MO 63011 in accordance with the specifications attached.

Sealed bids addressed to the City of Ballwin, 1 Ballwin Commons Circle, Ballwin, Missouri 63021 will be accepted by the City of Ballwin until 10:00 A.M. (prevailing local time) on the **5th day of May, 2026** at which time all bids received will be opened and read aloud. Bid Documents include this Notice to Contractors, Instructions to Bidders, General Conditions, the Plans and Specifications, Bid Proposal form, Bid Bond form, proposed City-Contractor Agreement, Bidders Information Sheet form, Exhibits, and any Addenda issued prior to closing of the scheduled time for accepting bids.

Bids should be clearly marked “BID OPENING: **Restroom Modernization: 26-16** Attn: Rob Jones.” Bids shall be submitted on the Bid Proposal form provided. All work shall be performed according to City of Ballwin specifications.

**Enrollment in Federal Work Authorization Program**

Bidders are informed that pursuant to Section 285.530, RSMo, as a condition of the award of any contract in excess of five thousand dollars (\$5,000.00), the successful bidder shall, by sworn affidavit and provision of documentation, affirm its enrollment and participation in a federal work authorization program with respect to the employees working in connection to the contracted services. Successful bidders shall also sign an affidavit affirming that it does not knowingly employ any person who is an unauthorized alien in connection to the contracted services.

**Safety Training**

Bidders are informed that the Project is subject to the requirements of Section 292.675, RSMo, which requires all contractors or subcontractors doing work on the Project to provide, and require its on-site employees to complete, a ten (10) hour course in construction safety and health approved by the Occupational Safety and Health Administration (“OSHA”) or a similar program approved by the Missouri Department of Labor and Industrial Relations which is at least as stringent as an approved OSHA program. The training must be completed within sixty (60) days of the date work on the Project commences. On-site employees found on the worksite without documentation of the required training shall have twenty (20) days to produce such documentation. Contractors and sub-contractors in violation of this provision will forfeit to the City of Ballwin \$2,500.00 plus \$100.00 a day for each employee who is employed without training. The City of Ballwin may withhold assessed penalties from payment due to the bidder and/or any subcontractors employed thereby. The bidder shall complete and submit their bid on the “AFFIDAVIT OF WORK AUTHORIZATION”.

A “Notice of Bid Award” is anticipated for **May 12, 2026**. However, work shall be TBD.

Bid security in the amount of five (5%) percent of the Base Bid offered by the bidder as indicated on the Bid Proposal form shall accompany the bid submittal. Bid security shall be in

the form of a bank draft or certified check drawn upon a responsible, solvent bank and payable to the City of Ballwin, Missouri or a satisfactory Bid Bond executed by the bidder and by a good and sufficient surety authorized to do business in Missouri.

The successful bidder shall be required to furnish within ten (10) days of notification of contract award a satisfactory Payment, Performance and Guarantee Bond in the full amount of the Bid based on the bid quantities listed on the Bid Proposal form. The Payment, Performance and Guarantee Bond furnished shall meet all requirements of section 107.170 of the Revised Statutes of Missouri, as amended, and shall guarantee the faithful performance of the work including payment of prevailing wage requirements of the State of Missouri. No bid submitted shall be withdrawn after the opening of bids for a period of ninety (90) calendar days after the closing of the scheduled time for accepting bids.

The bidder shall perform with his own organization, work amounting to not less than 50 percent of the total contract cost.

The City of Ballwin will affirmatively assure that in any contract entered into pursuant to this Notice to Contractors, qualified minority business enterprises will be afforded full opportunity to submit bids and will not be discriminated against on the grounds of race, color, religion, sex, age, disability, familial status, national origin or political affiliation. If you are a person that requires an accommodation or desires more information, please call (636) 227-8580 or RELAY MISSOURI 1-800-735-2966 TDD not later than 5:00 P.M. on the third day preceding the last day for accepting bids. Offices are open between 8:00 A.M. and 5:00 P.M. Monday through Friday.

The City of Ballwin intends to award a contract for the Project based on the bid that, in the City of Ballwin's sole discretion, best meets the interests and requirements of the City. The City of Ballwin reserves the right in the City's sole discretion to reject any and all bids, to waive technicalities or deficiencies in any or all bids, to negotiate with any or all bidders or others for more favorable terms or prices, and to award a contract to other than the bidder submitting the lowest cost bid proposal, with or without negotiation. The City of Ballwin reserves the right not to open a sole bid.

CITY OF BALLWIN, MISSOURI  
INSTRUCTIONS TO BIDDERS

**1. General**

A. All work shall be constructed and completed in accordance with the specifications for the same, relating to the construction of such improvements.

B. There will be no pre-bid meeting. If you would like to visit the site, or if you have any questions, contact Rob Jones, Superintendent of Parks & Facilities @ 636-227-2423, or at [rjones@ballwin.mo.us](mailto:rjones@ballwin.mo.us)

C. Bid due date is **May 5, 2026, at 10:00 A.M.** (prevailing local time).

**2. Scope**

Perform renovations to the restrooms at the Ballwin Golf Course Event Center, 333 Holloway Road, Ballwin, MO 63011 in accordance with the specifications attached.

**3. Material Purchases**

The Contractor shall be responsible for paying all material suppliers. The Contractor shall pay all taxes required by law. **For Sales Tax: see Special Sales Tax Provisions, paragraph 24.**

**4. Land and Rights-of-Way**

For the purposes of operating and maintaining the Project, the City of Ballwin shall acquire the necessary lands, easements and rights-of-way privileges required for the same. The Contractor shall furnish and construct any necessary access roads or facilities.

**5. Obtaining Bid Documents**

Bid Documents include the Notice to Contractors, the Instructions to Bidders, the General Conditions, the Plans and Specifications, the Bid Proposal form, the Bid Bond, the proposed City-Contractor Agreement, the Bidders Information Sheet form, Exhibits, and any Addenda issued prior to receipt of bid proposals and all modifications. Copies of the Bid Documents may be obtained at City of Ballwin, 1 Ballwin Commons Circle, Ballwin, MO 63021 at no cost. The City of Ballwin shall maintain a list of all persons and organizations who have obtained copies of the Bid Documents.

**6. Bid Proposals**

A. Sealed bid proposals will be received in accordance with the Notice to Contractors.

B. Bids shall be submitted on the accompanying Bid Proposal forms. Bids shall be sealed in an envelope bearing only the printed endorsement "**BID OPENING: Restroom Modernization 26-16, ATTENTION: ROB JONES**". In the case of proposals to be sent by mail, the envelope shall be placed in an outer or mailing envelope, and endorsed as noted above.

C. Bid security in the amount of five (5%) percent of the Base Bid [*exclusive of numbered Alternates*] as indicated on the Bid Proposal form shall accompany the bid submittal. Bid security shall be in the form of a bank draft or certified check and drawn upon a responsible, solvent bank and payable to the City of Ballwin, Missouri or a satisfactory Bid Bond executed by the bidder and by a good and sufficient surety authorized to do business in Missouri. The bid security shall be refunded or returned to the bidder upon the faithful performance of the conditions of the Bid Proposal to the satisfaction of the City of Ballwin.

D. The successful bidder shall be required within seven (7) days of receipt of written notification of award from the City of Ballwin to execute the City-Contractor Agreement and to furnish a satisfactory Payment, Performance and Guarantee Bond with a good and sufficient surety authorized to do business in the State of Missouri in the full amount of the bid submitted based on the bid quantity listed on the Bid Proposal form. The Payment, Performance and Guarantee Bond furnished shall meet all requirements of section 107.170 and 290.250 of the Revised Statutes of Missouri, as amended, and shall guarantee the faithful performance of the Work.

E. No bid shall be considered unless the offering bidder shall furnish evidence satisfactory to the City of Ballwin that the bidder has the necessary facilities, ability and pecuniary resources to fulfill the conditions of the Contract Documents. The low bidder or any other bidder may be required to submit financial statements.

F. All bids shall be made for materials in the different classes furnished in the Work complete, and no bid proposal will be made or considered on any part of the Work not complete in place, nor on materials except in completed work, unless specifically otherwise provided for in the Plans and Specifications.

G. Attention of the bidders is directed to the requirement that work on the project shall commence **TBD**.

H. No bid shall be withdrawn after the opening of bids for a period of ninety (90) calendar days after the closing time for acceptance of bids. Any bidder may withdraw a bid personally or by telegraphic or written request at any time prior to the closing time for the acceptance of bids.

I. The Contractor and each subcontractor engaged on the Project shall keep posted in a prominent and easily accessible place at the Project site a clearly legible statement of all prevailing hourly wage rates to be paid to all workers employed on the construction of the Project. The statement shall remain continuously posted during the full time that any worker shall be employed on the Project.

J. Bidder shall perform with his own organization, work amounting to not less than 50 percent of the total contract cost.

## 7. Itemized Bids

Each bid shall be itemized in component parts as set out on the Bid Proposal form to be submitted on or before the date and time for receiving bids. Each bid shall specify unit prices for all items and shall make extensions based upon the quantities listed. The sum of the products of the quantities listed in the Bid Proposal form as submitted, multiplied by the unit price bid, shall constitute the gross sum bid.

## 8. Bidder's Duties

A. Bidders shall thoroughly examine the Plans and Specifications for the Project, and also the Project site, shall inform themselves fully of the conditions relating to construction and labor under which the Work will be performed and shall judge for themselves all the circumstances affecting the cost and nature of the Work and the Project. By submitting a bid, each bidder represents that the bidder has inspected the Project site and is thoroughly familiar with the Bid Documents and all requirements for performance of the Work and failure of the bidder to do so shall not relieve the successful bidder of the obligation to furnish all labor, materials and equipment necessary to carry out the provisions of the Contract Documents and to complete the Project in accordance with the Contract Documents for the consideration set forth in the bid submitted.

B. The Contractor shall employ, insofar as possible, such methods and means in carrying out the Work as will not cause any interruption or any interference with any other contractor.

C. In a case of doubt as to the true meaning of any part of the Plans and Specifications, or any other of the Bid Documents, any person who has obtained a copy of the Bid Documents may submit to the City of Ballwin a written request for an interpretation thereof. The person submitting the request shall be responsible for its prompt delivery. Any such interpretation will be rendered only by written addendum duly issued and a copy of such addendum will be mailed or delivered to each person listed by the City of Ballwin as having obtained a copy of the Bid Documents. The City of Ballwin shall not be responsible for any other explanation or interpretation of the Bid Documents.

D. To be considered, each bid submitted shall be accompanied by at least three (3) references regarding prior work of the bidder on public works contracts in Missouri.

## 9. Bidder Disqualifications

No contract will be awarded by the City of Ballwin to any person, firm or corporation: (i) who has been delinquent or unfaithful in any other prior contract for construction with the City of Ballwin; (ii) who has defaulted as surety or otherwise upon any contractual monetary obligation to the City of Ballwin; (iii) who appears on the Missouri Secretary of State's list of violators of the Prevailing Wage Law.

**10. Return of Bid Security**

The City of Ballwin shall return the bid security of all except the three apparent lowest bidders for the Project within three (3) business days after the opening of bids. Bid security of the three apparent lowest Bidders shall be returned within 48 hours after the City of Ballwin has accepted a Payment, Performance and Guarantee Bond and has approved and executed a City-Contractor Agreement.

**11. Right To Reject Bids**

The City of Ballwin intends to award a contract based on the bid that, in the City of Ballwin’s sole discretion, best meets the interests and requirements of the City. The City of Ballwin reserves the right in the City’s sole discretion to reject any and all bids, to waive technicalities or deficiencies in any or all bids, to negotiate with any or all bidders or others for more favorable terms or prices, and to award a contract to other than the bidder submitting the lowest cost bid proposal, with or without negotiation. The City of Ballwin reserves the right not to open a sole bid.

**12. Insurance**

The Contractor shall obtain and maintain during the term of the Project and the City-Contractor Agreement the insurance coverages set forth in this paragraph. Insurance policies providing required coverages shall be with companies licensed to do business in the State of Missouri and rated AA by Best or equivalent. All costs of obtaining and maintaining insurance coverages shall be included in the bid and no additional payment will be made therefore by the City of Ballwin.

Minimum coverages and amounts

Employer's Liability	\$2,000,000 each person
Comprehensive Automobile Liability Insurance	\$2,000,000 each person
Bodily Injury	\$2,000,000 each accident
Property Damage	\$1,000,000 each accident
Comprehensive General Liability Insurance	\$2,000,000 each person
Bodily Injury	\$2,000,000 each person
Property Damage	\$1,000,000 each aggregate

In addition, the Contractor and all subcontractors shall provide Worker’s Compensation Insurance in at least statutory amounts for all workers employed at the Project site. *[The Contractor shall also provide a policy of Builder’s Risk Insurance in the amount of 100% of the*

*complete insurable value of the Project, which policy shall protect the Contractor and the City of Ballwin, as their respective interests shall appear].*

Before commencing any work, the Contractor shall provide to the City of Ballwin certificates of insurance evidencing the issuance and maintenance in force of the coverages required by this paragraph. Each such certificate shall show the City of Ballwin as an additional insured and shall bear an endorsement precluding cancellation of or change in coverage without at least thirty (30) days written notice to the City of Ballwin.

### **13. Delays, Extensions of Time**

A. Should the Contractor be delayed at any time during the execution of the Work by changes in the scope of work, or by strikes, lockouts, fire, unusual transportation delays, unavoidable casualties, or other delay beyond the control of and not reasonably foreseeable by the Contractor and such delay is approved by the City of Ballwin, the time for completion shall be extended for a period commensurate with the period of the delay.

B. In such event, the Contractor may submit a written request for a time extension within seven (7) calendar days of the occurrence of the event causing the delay.

C. Inclement weather shall not be considered a valid reason for extension of time, unless abnormal for the season and place of work. The Contractor shall make proper allowance for inclement weather in the bid submitted.

D. In case of continuing delay, a single request for time extension by the Contractor shall be sufficient.

### **14. Liquidated Damages**

In submitting a bid, the Contractor agrees and acknowledges that time is of the essence and that a delay in the prosecution of the work and the project will inconvenience the public and increase administrative costs of the City of Ballwin, the costs of which the Contractor and the City of Ballwin are incapable of ascertaining at this time. Should the Contractor, or in the case of the Contractor's default, the surety, fail to complete the work within the time stipulated in this agreement, or within an extension of time as may be allowed by the City of Ballwin set forth in paragraph 14, above, the Contractor (or surety, as applicable) shall pay to the City of Ballwin as liquidated damages, and not as a penalty, the sum of Four Hundred Seventy Five Dollars (\$475.00) for each calendar day that the work remains uncompleted after the time allowed for completion, including approved extensions. In the sole discretion of the City of Ballwin, the amount of liquidated damages may be deducted from any money due the contractor under this agreement. Permitting the Contractor to finish the work or any part thereof after the expiration of the time for completion or any approved extension, shall in no way operate as a waiver of the City of Ballwin of any rights under this agreement.

**15. Observation and Final Inspection**

A. The City of Ballwin shall have access at all times to the Project for the purpose of observation. The Contractor shall provide proper and adequate facilities for such access and observation.

B. When the Contractor has completed all Work, the City of Ballwin shall make a final inspection to determine conformity to the Contract Documents. The Contractor shall provide, at the Contractor's sole expense, all equipment and assistance necessary for such final inspection, including all tests specified herein or required by law. All cost for providing such equipment and assistance shall be included in the bid submitted and no additional payment therefore will be made by the City of Ballwin.

**16. Coordination**

A. The Contractor shall contact and coordinate with all affected utilities prior to commencing any operations.

B. The Contractor shall coordinate operations with the City of Ballwin. As a minimum, the Contractor shall notify the Superintendent of Parks & Facilities at least 72 hours prior to commencement of work. The Contractor shall additionally provide the Park Superintendent with the name and phone number of a responsible contact person for after hours and weekend emergencies.

**17. Permits and Licenses**

Prior to commencing any work on the Project, the Contractor shall secure and pay for all permits and licenses from all agencies having jurisdiction over the Project, including by way of illustration, the City of Ballwin.

**18. Inspection and Maintenance**

A. The City of Ballwin will provide inspection on this Project. The Contractor shall be responsible for notifying the Superintendent a minimum of 48 hours prior to scheduling of a required inspection.

B. Any material or workmanship which the Superintendent determines does not meet requirements of the Specifications will be rejected. At the direction of the Superintendent, the Contractor shall remove and replace the rejected material with acceptable material at no cost to the City.

C. The Contractor shall be responsible for keeping clean, i.e. free from mud, dirt, rock, and debris at all times all City streets used by the Contractor in connection with the Work and the Project. Should any accumulation be deemed excessive, the Superintendent may direct the Contractor to thoroughly wash or remove the debris from the street at no cost to the City.

**19. Award of Contract**

Except in cases where the City of Ballwin exercises the right to reject any or all bids or to negotiate with any or all bidders, the City of Ballwin will award a contract for the Work and the Project as soon as practicable after closing of the time for accepting bids, to the bidder who has submitted the lowest bid which complies in all respects with requirements of the Bid Documents.

**20. Progress Payments**

A. The Contractor shall submit requests for payment not more than once monthly. All requests for payment shall be itemized and shall reflect an estimate of the proportionate value of work actually performed at the Project site through the last day of the previous month. With each monthly request, the Contractor shall additionally submit partial lien waivers for work covered by the request for payment. Lien waivers for all Work shall be required prior to final acceptance. Ten percent (10%) of the amount of each monthly request for payment shall be withheld until after completion by the Contractor and acceptance by the City of Ballwin of all Work.

B. No progress payment made by the City of Ballwin except the certificate of final payment, shall be evidence of the satisfactory performance of the Work, either wholly or in part. No payment made by the City of Ballwin shall be construed to be an acceptance of work or materials determined to be defective or improper.

**21. Special Sales Tax Provisions**

The City of Ballwin intends to take maximum advantage of the City's sales tax exemption status. Accordingly, CONTRACTORS SHALL NOT INCLUDE SALES TAX IN BID PROPOSAL AMOUNTS. Compliance with these procedures is COMPULSORY and for the benefit of the City of Ballwin.

REQUIREMENTS INCLUDE:

A. CITY OF BALLWIN shall:

Furnish the Contractor a "Project Tax Exemption Certificate" which shall include the following:

1. City of Ballwin's name, address, Missouri tax identification number and signature of authorized representative;
2. The project location, description, and unique identification number;
3. The date the City-Contractor Agreement is entered into, which is the earliest date materials may be purchased for the project on a tax-exempt basis;

4. **The date of completion for the Project; TBD**
  5. The Tax Exemption Certificate expiration date. Such certificate is renewable for a given project at the option of the City of Ballwin, only for the purpose of revising the certificate expiration date as necessary to complete the Project.
- B. THE CONTRACTOR shall:
1. Furnish the Project Tax Exemption Certificate to all subcontractors. The Contractor and any subcontractor purchasing materials shall present, on behalf of the City of Ballwin, all tangible personal property and materials to be incorporated into or consumed in the construction of the Project and no other on a tax-exempt basis. **SUPPLIERS SHALL EXECUTE TO THE PURCHASING CONTRACTOR OR SUBCONTRACTOR INVOICES MADE OUT TO THE CONTRACTOR. THE INVOICES MUST ALSO BEAR THE NAME OF THE CITY OF BALLWIN AND THE PROJECT IDENTIFICATION NUMBER.** Nothing in this section shall be deemed to exempt the purchase of any construction machinery, equipment, or tools used in constructing, repairing or remodeling facilities for the City of Ballwin. All invoices for all personal property and materials purchased for the Project utilizing the Project Tax Exemption Certificate shall be retained by the purchasing Contractor or subcontractor for a period of five (5) years and shall be subject to audit by the Missouri Director of Revenue.
    - a. Any excess re-salable tangible personal property or materials which were purchased for the Project by the Contractor or subcontractor under the Project Tax Exemption Certificate but which were not incorporated into or consumed in the construction of the Project shall either be returned to the supplier for credit or the appropriate sales or use tax on such excess property or materials shall be paid by the Contractor or subcontractor not later than the due date on the Contractor or subcontractor's Missouri sales or use tax return following the month in which it was determined that the materials were not to be used in the Project.
    - b. No Contractor, subcontractor or material supplier shall, upon audit, be required to pay tax on tangible personal property and materials incorporated into or consumed in the construction of the Project, due to the failure of the City of Ballwin to revise the certificate expiration date as necessary to complete any work required. If it is determined that tax is owed on such property and materials due to the failure of the City of Ballwin to revise such certificate expiration date, the City of Ballwin shall be liable for the tax owed.
  2. Order all necessary materials and equipment (materials) to complete the Work and the Project in accordance with the Plans and Specifications.
  3. Inspect all delivered materials for conformance to specifications, damage, or breakage and subsequently accept materials if found to be satisfactory.
    - a. Purchase of materials on behalf of the City of Ballwin shall not relieve the Contractor of obligations to order, schedule deliveries, inspect, accept, or reject, store, handle or install materials or perform any other duties required by the

Contract Documents or customarily performed in conjunction with providing materials to complete the Work.

- b. Costs of complying with the foregoing Special Sales Tax Provisions shall be included in the Bid Proposal submitted and the Contractor shall not be entitled to receive additional compensation for such compliance.

## **22. Damage to Site**

Contractor will repair any damage done to pavement, concrete, brick, curbing, tile, building or any other property damaged by this project.

## **23. OSHA Compliance**

The City of Ballwin supports safety in the workplace as set forth in the Occupation Safety & Health Act (OSHA). A record of violations, without evidence of correction measures taken, may result in the rejection of a contractor's bid.

**AFFIDAVIT OF WORK AUTHORIZATION**

Comes now \_\_\_\_\_ (name) as \_\_\_\_\_  
 (office held) first being duly sworn, on my oath, affirm \_\_\_\_\_  
 (company name) is enrolled and will continue to participate in a federal work  
 authorization program in respect to employees that will work in connection with the  
 contracted services related to \_\_\_\_\_ (bid number) for the duration of the contract, if  
 awarded in accordance with RSMo Chapter 285.530 (2). I also affirm that  
 \_\_\_\_\_ (company name) does not and will not knowingly  
 employ a person who is an unauthorized alien in connection with the contracted services  
 related to \_\_\_\_\_ (bid number) for the duration of the contract, if awarded.

***In Affirmation thereof, the facts stated above are true and correct (The undersigned understands that false statements made in this filing are subject to the penalties provided under Section 575.040, RSMo).***

\_\_\_\_\_  
 Signature (person with authority) Printed Name

\_\_\_\_\_  
 Title Date

Subscribed and sworn to before me this (day) of (month, year). I am commissioned as a notary public within the County of (name of county), State of (name of State), and my commission expires on (date).

\_\_\_\_\_  
 Signature of notary Date

**Specifications**

- 1. This scope of work is limited to the Ballwin Event Center. Remodeling of the men’s and women’s restrooms
- 2. No change HVAC, plumbing & fire sprinklers
- 3. Reference **General Notes** on **Page 7** of the Architectural drawings

**PROJECT OBJECTIVE**

To perform renovations to the restrooms at the Ballwin Golf Course Event Center, 333 Holloway Road, Ballwin, MO 63011 in accordance with the Architectural drawings attached.

**PROJECT SCHEDULE**

- Anticipated award of the **May 12, 2026**
- Work shall commence **preferably August 3,2026 or agreed upon date.**
- Guaranteed completion date: \_\_\_\_\_

**PRICE TO COMPLETE PROJECT AS SPECIFIED ABOVE: \$** \_\_\_\_\_

**DEDUCT ALTERNATE FOR CITY TO COMPLETE DEMOLISION: \$** \_\_\_\_\_

Name \_\_\_\_\_

Company \_\_\_\_\_

Address \_\_\_\_\_

Phone \_\_\_\_\_

Email \_\_\_\_\_

Signature \_\_\_\_\_ Date \_\_\_\_\_

BID PROPOSAL

Project: The proposed project will consist of demolition and renovation work in the restrooms at the Ballwin Golf Course Event Center, 333 Holloway Rd. Ballwin, MO 63011 in accordance with the specifications attached.

\_\_\_\_\_, a:  
(Name of Bidder)

- (check one)  corporation organized and existing under the laws of the State of \_\_\_\_\_  
 \_\_\_\_\_ partnership  
 individual doing business as \_\_\_\_\_  
 other (specify) \_\_\_\_\_

\_\_\_\_\_

(hereinafter, the “Bidder”), having carefully examined the Bid Documents including the Plans and Specifications for the Project, which Bid Documents are hereby made a part of this Bid Proposal, the Project site and all conditions relating to construction and labor under which the Work will be performed, hereby propose and agree to furnish all necessary machinery, tools, apparatus and other means of construction, and to perform all Work and furnish all the materials specified in the Contract Documents in the manner and time therein prescribed, and in accordance with the Unit Price Extension Sheet attached hereto. The Bidder specifically understands and acknowledges that the quantities given in the following itemized Unit Price Extension Sheet are not guaranteed by the City of Ballwin and are used solely for the purpose of comparing bids and awarding a contract, and may or may not represent the actual quantities encountered on the Project and that the total price paid for the Work will be adjusted based upon actual quantities of work performed or supplied. Any such adjustments will be made at the unit prices provided in this Bid Proposal.

Bid security in the amount of five (5%) percent of the Base Bid indicated on the Unit Price Extension Sheet in the form of:

- (check one)  a bank draft or certified check payable to the City of Ballwin, Missouri,  
 a Bid Bond executed by the Bidder and by a good and sufficient surety,

which is attached to this Bid Proposal, is hereby posted in accordance with the Instructions to Bidders. For purposes of this paragraph, the Base Bid shall be *[insert either (i) “the sum of the products of the quantities listed, multiplied by the unit price as extended on the attached Unit Price Extension Sheet”; or (ii) “the Base Bid as extended on the attached Unit Price Extension Sheet, exclusive of any numbered Alternates.”]*

If notified by the City of Ballwin in writing of the acceptance of this Bid Proposal within ninety (90) days of the scheduled date for receipt of bids, the Bidder agrees to within seven (7) days of receipt of such written notification (i) execute the City-Contractor Agreement to perform the Work for above stated compensation; and (ii) furnish a satisfactory Payment, Performance and Guarantee Bond with a good and sufficient surety in the full amount of the submitted Base Bid set forth on the attached Unit Price Extension Sheet and accepted by the City of Ballwin. The

Bidder hereby acknowledges and agrees that in the event of the Bidder's failure to comply in all respects with this paragraph, the accompanying Bid security shall be declared forfeit.

\_\_\_\_\_, BIDDER  
(Legal Name of Person, Firm or Corporation)

\_\_\_\_\_  
Signature of Authorized Representative

\_\_\_\_\_  
Date

Attested by:

\_\_\_\_\_  
Typed Name

\_\_\_\_\_

\_\_\_\_\_  
Title

\_\_\_\_\_  
Title

\_\_\_\_\_  
Bidder's Street Address

\_\_\_\_\_  
Bidder's Telephone Number

\_\_\_\_\_  
City, State, Zip

\_\_\_\_\_  
Bidder's Fax Number

## CITY-CONTRACTOR AGREEMENT

THIS CITY CONTRACTOR AGREEMENT (this “Agreement”), is made and entered into as of this 12th day of May, 2026, by and between \_\_\_\_\_ a contractor having a principal office at \_\_\_\_\_ (the “Contractor”), and the City of Ballwin, a Missouri municipal corporation located in St. Louis County (the “City”). *All capitalized terms used and not defined herein shall have the meanings ascribed to them in the Contract Documents (as hereinafter defined).*

## RECITALS

A. In response to RFP 26-16 of the City requesting bid proposals for the demolition and renovation work to the interior of the maintenance facility at the Ballwin Golf Course, 333 Holloway Rd. Ballwin, MO 63011, the Contractor has submitted a certain Bid Proposal in accordance with the Bid Documents to perform the Work.

B. After due consideration, the City has accepted the Bid Proposal of the Contractor and the parties hereto desire to enter into this Agreement whereby the Contractor shall undertake the performance of the Work in accordance with the Contract Documents and the City shall pay the Contractor as hereinafter specified.

## AGREEMENT

NOW, THEREFORE, in consideration of the foregoing recitals and of the mutual promises hereinafter set forth the City and the Contractor hereby agree as follows:

1. **Contract Documents.** This Agreement shall consist of: (i) RFP 26-16 including, without limitation, the Notice to Contractors, the Instructions to Bidders, the General Conditions, the Plans and Specifications, the Bid Proposal form, the Bid Bond, the proposed City-Contractor Agreement, the Bidders Information Sheet form, and any Exhibits; (ii) Addenda numbered #1; (iii) the Bid Proposal of the Contractor dated \_\_\_\_\_, **2026** (the “Proposal”); (iv) the Payment, Performance and Guarantee Bond submitted by the Contractor; and (v) this City-Contractor Agreement and exhibits attached thereto (all of the foregoing collectively referred to as the “Contract Documents” are hereby incorporated in this Agreement by reference).

2. **The Work.** The Contractor shall furnish all labor, materials, tools, equipment and services, and perform and complete the Work required for the Project in accordance with this Agreement which shall include provision of every item specified in the Contract Documents necessary to complete the Project as designed.

3. **Time of Completion.** Contractor shall fully complete the project no later than \_\_\_\_\_ . The parties understand that time is of the essence and that the rate of progress and prompt completion are essential conditions, and that in the event the Work is not fully completed within the period provided herein, the Contractor shall pay to the City the sums provided in the Contract Documents. Liquidated damages shall amount to Four Hundred Seventy Five Dollars (\$475.00) for each calendar day that the work remains uncompleted after the time allowed for completion, including approved extensions.

4. **Acceptance and Payment.** When the Work has been fully completed in accordance with the Contract Documents, the City shall make a final inspection, and any defects arising out of said inspection shall be promptly remedied by the Contractor at no additional cost to the City. After final acceptance of the Work by the City, the City shall pay the Contractor the amounts required by the Contract Documents including any amounts held by the City as retainage, less any progress payments made previously and less any moneys which are due and payable to the City as liquidated damages.

5. **Guaranty.** The Contractor hereby expressly guarantees the aforesaid Work as to workmanship for a term of one (1) year and quality of materials used in connection herewith for a term of two (1) year, commencing on the date of final acceptance by the City, and binds itself, its successors or assigns, to make all replacements which may become necessary within said period due to construction defects and nonconformity with the Contract Documents. Whenever notified by the City that said replacements are required, the Contractor shall at once make the same as directed at its own expense.

6. **Compliance with Federal, State and Local Law.** The Contractor shall comply with all applicable federal, state and municipal law requirements for performance under this Agreement. The Contractor shall abide by all health and environmental requirements imposed by law in performance of its duties. It shall be the obligation of the Contractor to require this provision to be included in all subcontracts.

7. **Taxes.** The City is exempt from federal excise tax and Missouri sales tax and the Contractor shall not charge the same to the City and shall comply in all respects with the Special Sales Tax Provisions of the Contract Documents.

8. **Other Representations, Warranties and Other Covenants by the Contractor.** The Contractor represents and warrants that the Contractor has been engaged in such work as is required for the Project and has provided services such as the ones to be performed under this Agreement to other municipalities and/or private enterprises and that the Contractor owns sufficient equipment and engages sufficient personnel to perform the Contractor's obligations under this Agreement. The Contractor further represents and warrants that the Contractor is an equal opportunity employer. The Contractor agrees that the Contractor shall not use in any form or medium the name of the City for any advertising unless the Contractor receives the prior written consent of the City. If necessary, during periods of work the traveling public will be adequately protected and advised with appropriate signs, barricades, cones and flaggers as deemed necessary or as directed by the City of Ballwin. In the case of open excavations or other potentially hazardous conditions existing during non-working periods, the traveling public will be protected and advised by signs and flasher barricades. Parking of equipment or storage of materials on or near the Project site will be permitted only if adequate protective devices are provided and then only for the minimum time required for any specific job. Prior to entering, parking equipment or storing materials on private property the Contractor shall obtain written permission from the property owner. Prior to commencement of any work involving excavation, demolition of facilities or the erection of posts, it will be the sole responsibility of the Contractor to notify all utilities of the planned work and request that the utilities suitably mark underground installations in the vicinity of the planned work, and arrange for disconnection of any necessary utilities. For any operations involving the purchase and/or drayage of materials, the Contractor will be required to submit lien waivers to the City prior to payment for the work. In addition, the Contractor may be required to submit payroll affidavits to the City attesting that the labor has

been paid for work on the Project at the proper wage scale. These provisions do not apply to any materials, drayage or labor furnished or supplied by the City.

9. **Amendment; Waiver.** No amendment, modification or waiver of any provision of this Agreement shall be effective unless in writing signed by an authorized representative of the party against whom such provision as amended or modified or such waiver is sought to be enforced. Failure to insist upon strict compliance with any of the terms or conditions of the Agreement shall not be deemed a waiver of such term or condition.

10. **Choice of Law.** This Agreement shall be governed by and construed and interpreted in accordance with the internal laws of the State of Missouri, without regard to its principles of conflict of laws.

11. **Headings.** The paragraph and section headings contained herein are for convenience only and are not intended to limit, vary, define or expand the content thereof.

12. **Severability.** The invalidity or unenforceability of any portion or provision of this Agreement shall not affect the validity or enforceability of any other portion or provision of this Agreement, which shall remain in full force and effect to the maximum extent permitted by law.

13. **Counterparts.** This Agreement may be executed in one or more counterparts each of which shall be deemed an original and all of which shall constitute one and the same agreement.

IN WITNESS WHEREOF, the parties hereto have caused this instrument to be executed as of the day and year first above written.

CONTRACTOR

CITY OF BALLWIN

\_\_\_\_\_  
Name

\_\_\_\_\_  
City Administrator

\_\_\_\_\_  
Address

\_\_\_\_\_  
Attested

\_\_\_\_\_  
City, State, Zip

\_\_\_\_\_  
Date

By: \_\_\_\_\_

COUNTERSIGNED

\_\_\_\_\_

\_\_\_\_\_  
Title

**PROJECT CODE DATA**

**Ballwin Event Center**

ZONING	Ballwin Municipal Proerty
CODES	City of Ballwin Building Codes IP <u>2021</u> Health Department West County Fire & EMS
USE GROUP CLASSIFICATION " A "	Group A- 2 Assembly - Banquet Hall

**SCOPE OF WORK**

EXISTING BUILDING STRUCTURE - No additions or interior wall alterations required.  
 EXTERIOR ALTERATIONS - None  
 INTERIOR ALTERATIONS - Fixture and décor updating i.e. general remodeling of existing Women's and Men's Restrooms.  
 UTILITIES - No change

**BUILDING SHELL CONSTRUCTION TYPE**

Pg 87 Table 601 - Type 1B Protected  
 Pg 86 One story building. Structural wood framing, slab on grade.

**PROPOSED TENANT USEAGE**

Special event service operations i.e. weddings and special events.

OCCUPANCY LOAD	Gross SF	Event SF	SF / Person	Max Occupant
<b>EVENT SPACE</b>	1800	1400	7	200
A 2 Assembly - IBC pg 521 - Table 2902.1				

RESTROOM MINIMUM FIXTURE REQUIREMENTS		MEN	WOMEN
	WC	1 per 150	1 per 75
	Lavatories	1 per 200	1per 200
MEN (ASSUME 100 PERSONS)		REQUIRED	PROVIDED
	WC	2	2
	Urinals	2	3
	Lavatories	1	2
WOMEN (ASSUME 100 PERSONS)			
	WC	2	4
	Lavatories	2	2

**NUMBER OF EGREES EXITS 4**

Sec 1019.3 Pg223  
 Pg 216 EXIT signage ICC A117.1 compliant.

**AUTOMATIC FIRE SUPPRESSION - Yes**

**FIRE EXTINGUISHERS** Fire Extinguishers NFPA 10, IBC 906 and IFC 906.

**ALARM & DETECTION - By Others**

**UTILITIES - Electric, Gas, Water & Sewer**

**PARKING & EXTERIOR LIGHTING** Existing No Change

**JIM WOODWORTH**  
**architect**  
 1055 Woodfield Estates Dr.  
 Town & Country, MO 63017  
**314-277-7552**  
 FAX 314-576-3503  
 jpwoodworth@att.net

*Jim Woodworth*

**RESTROOM REMODELING**  
**BALLWIN EVENT CENTER**  
 333 Holloway Road  
 Ballwin, MO 63011



March 10, 2026

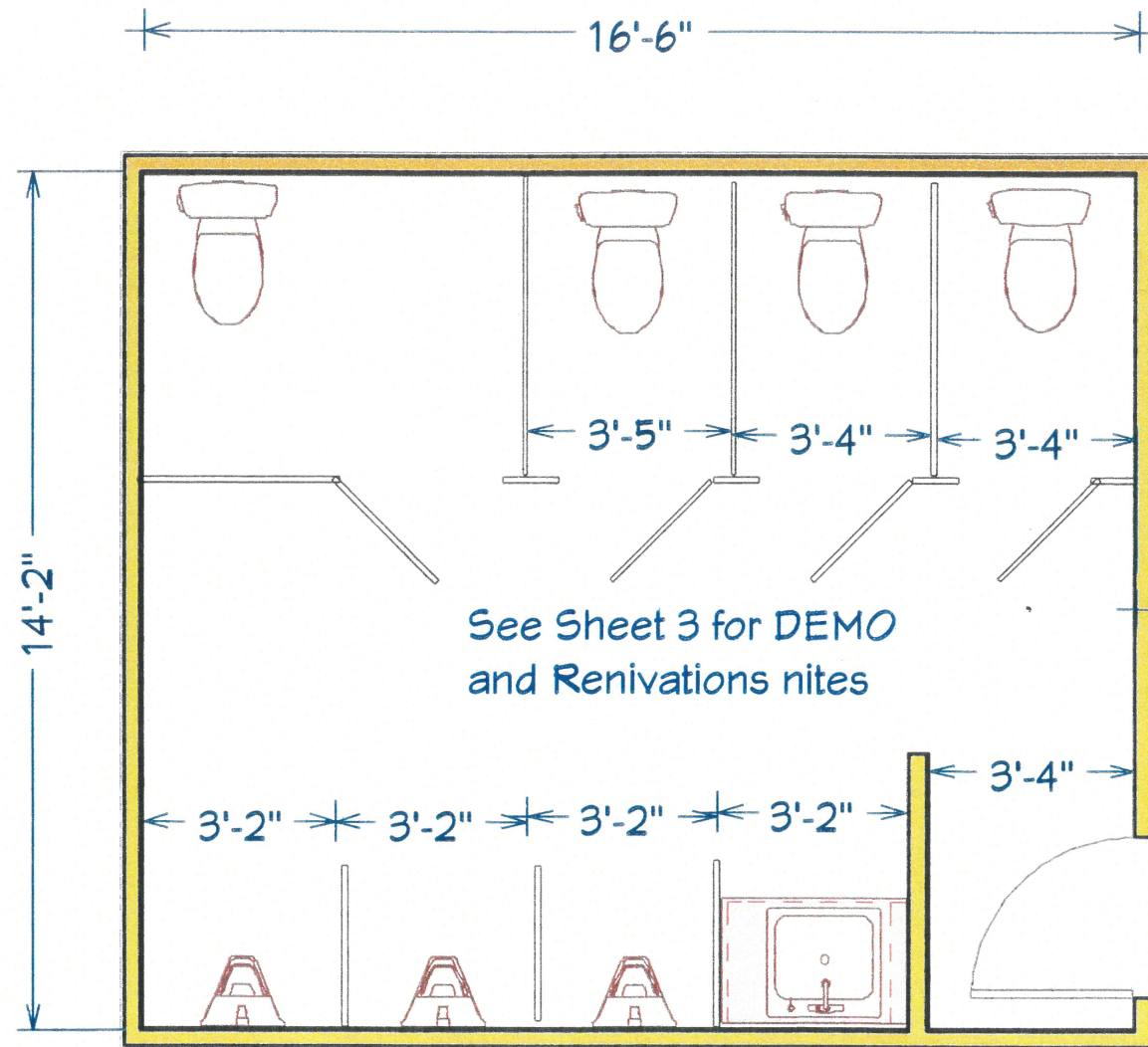

**DEMO EXISTING PLAN**

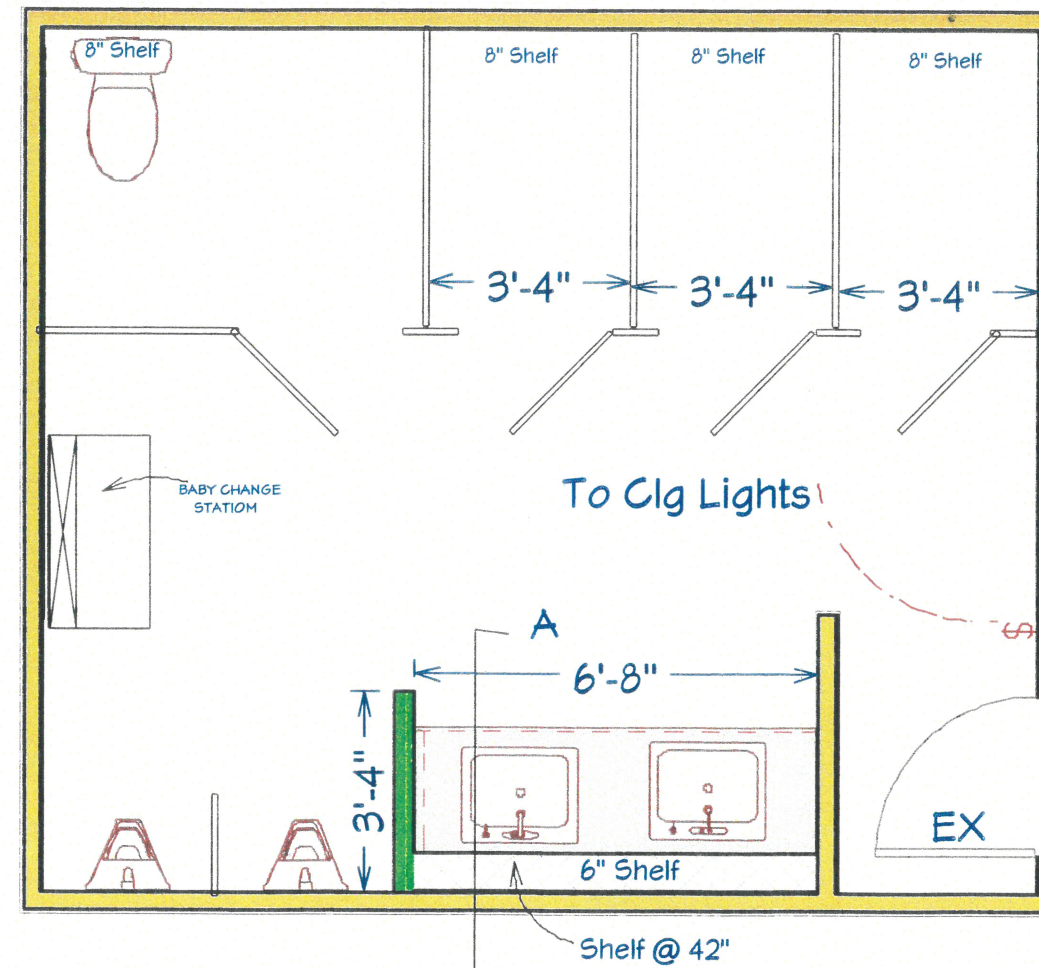

**NEW ALTERATONS**

**MEN RESTROOM**  
**FLOOR PLANS**  
**BALLWIN EVENT CENTER**  
 333 Holloway Road  
 Ballwin, MO 63011



March 10, 2026

**DEMOLITION WORK**

**NO CHANGE**

- Fire Sprinklers

(S)  
 EXISTING  
 FIRE SPRINKLER

**DEMO**

- 2x4 Flour. Lights
- All toilet fixtures
- All wall mounted
- All Ceramic Tile

**REPAIR / RELOCATE / UPDATE**

- All electrical switches & receptacles
- RA (return air duct)
- Suspended Ceiling

**SALVAGE FOR REUSE**

- Toilet Stall partitions
- All wall mounted restroom accesories

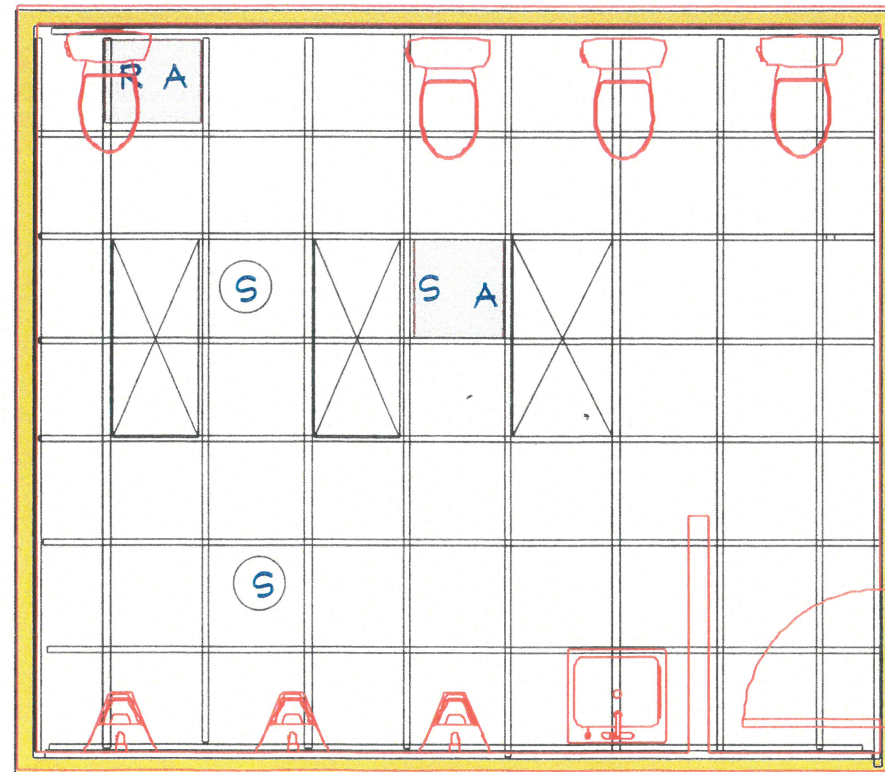

**EXISTING  
 REFLECTED CEILING PLAN**

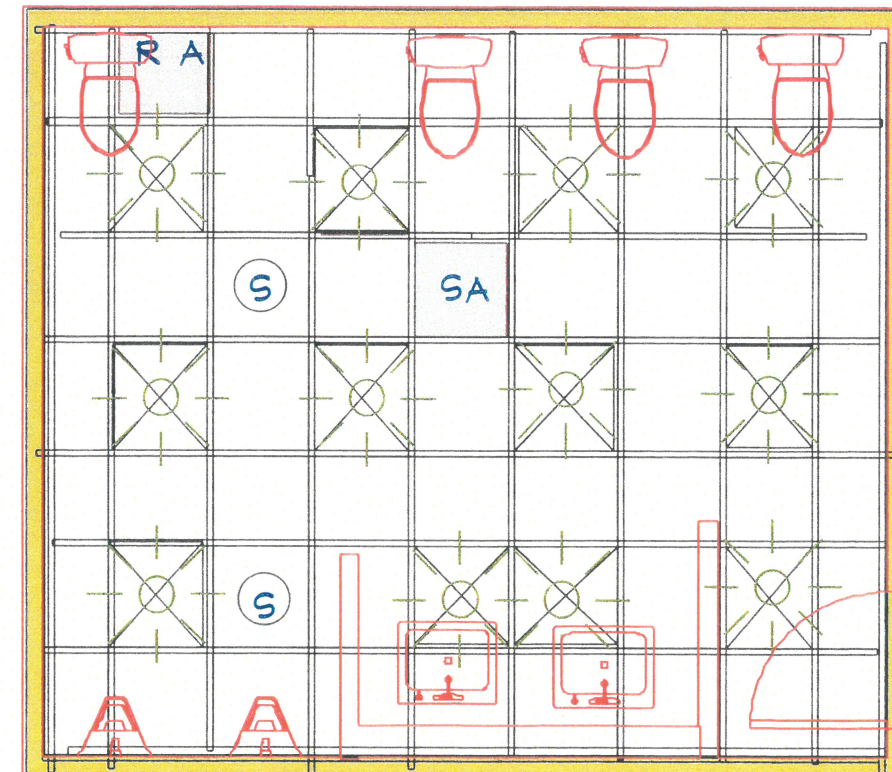

**ALTERATIONS  
 REFLECTED CEILING PLAN**

**MEN RESTROOM  
 REFLECTED CELING PLANS  
 BALLWIN EVENT CENTER  
 333 Holloway Road  
 Ballwin, MO 63011**

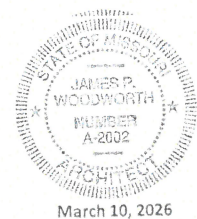

March 10, 2026

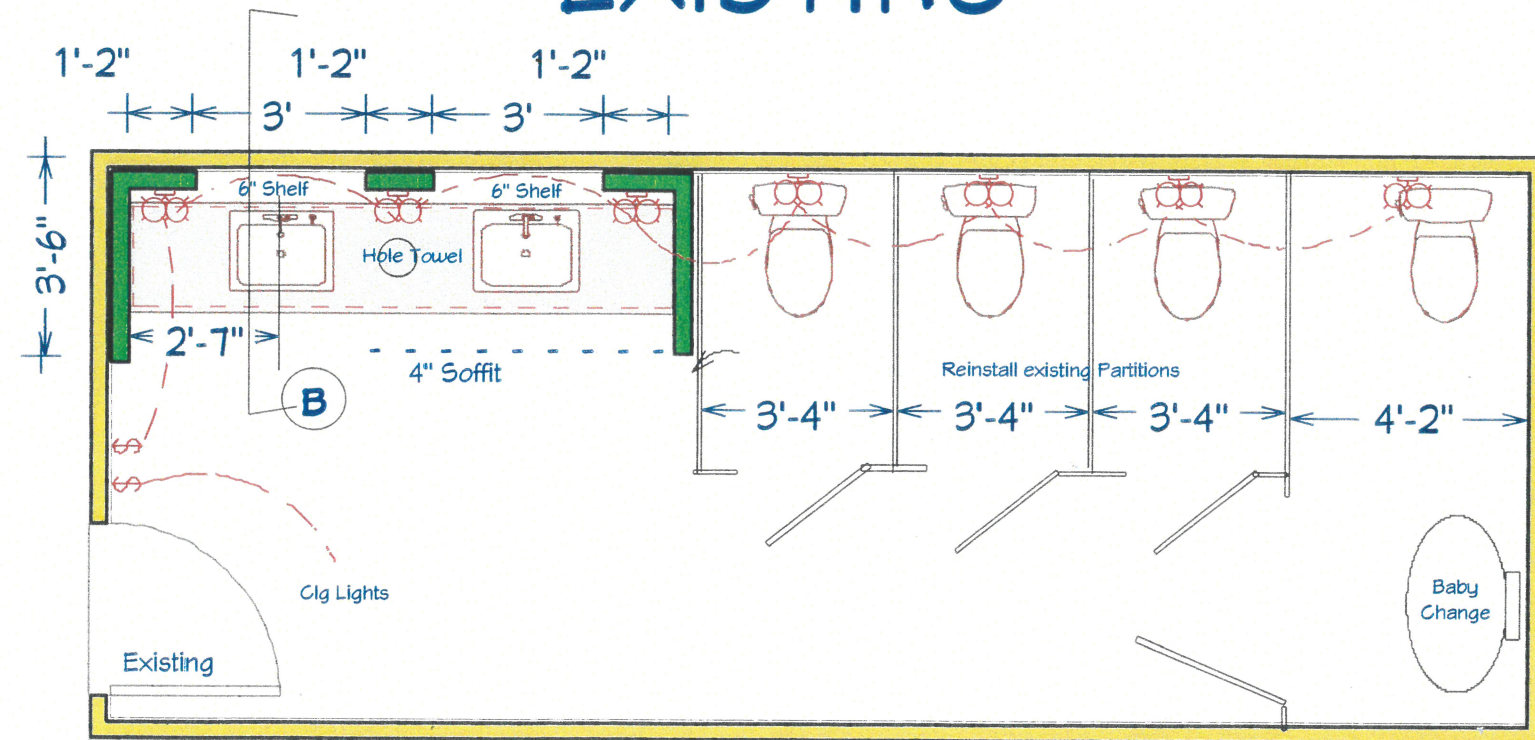
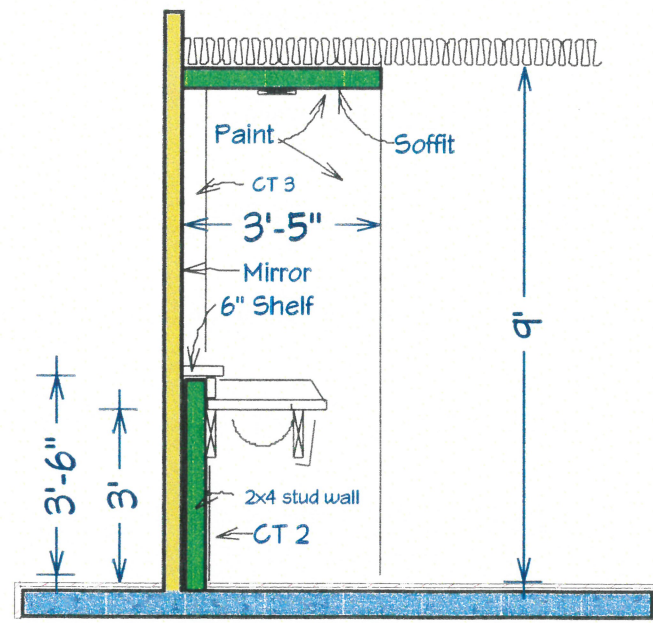
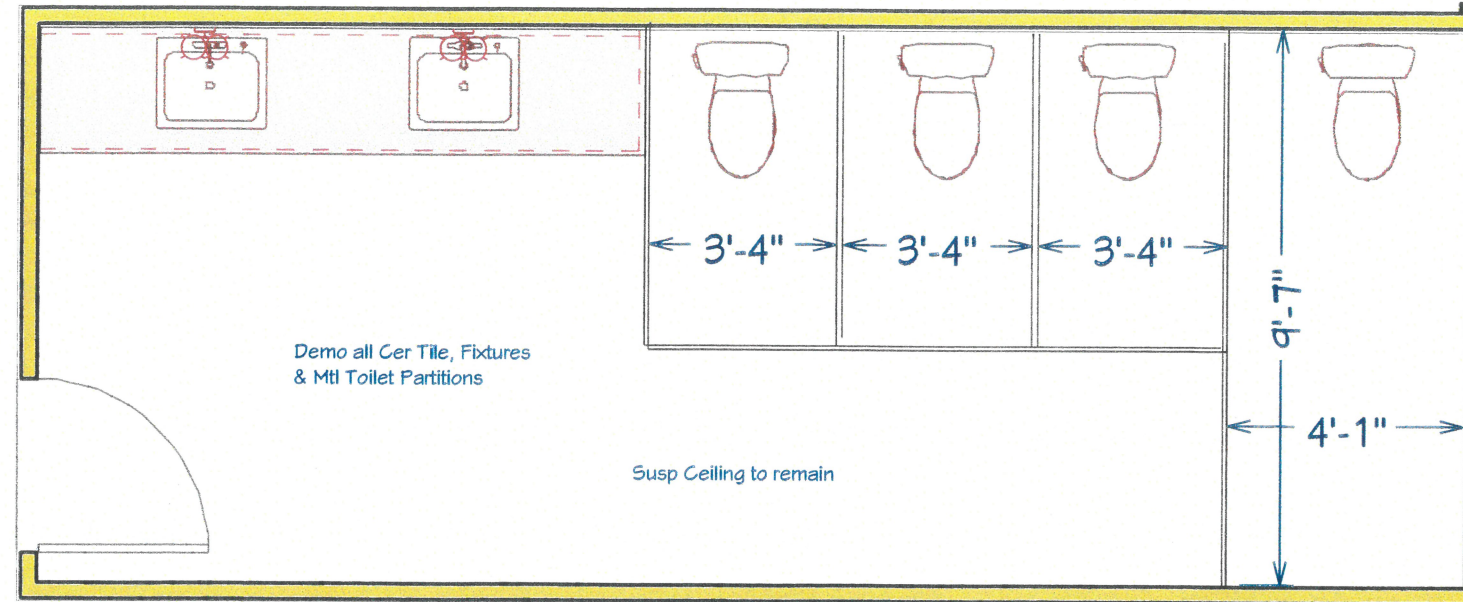

**WOMEN RESTROOM**  
**FLOOR PLANS**  
**BALLWIN EVENT CENTER**  
 333 Holloway Road  
 Ballwin, MO 63011

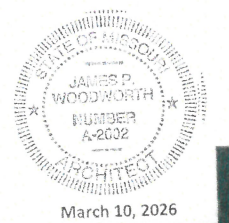

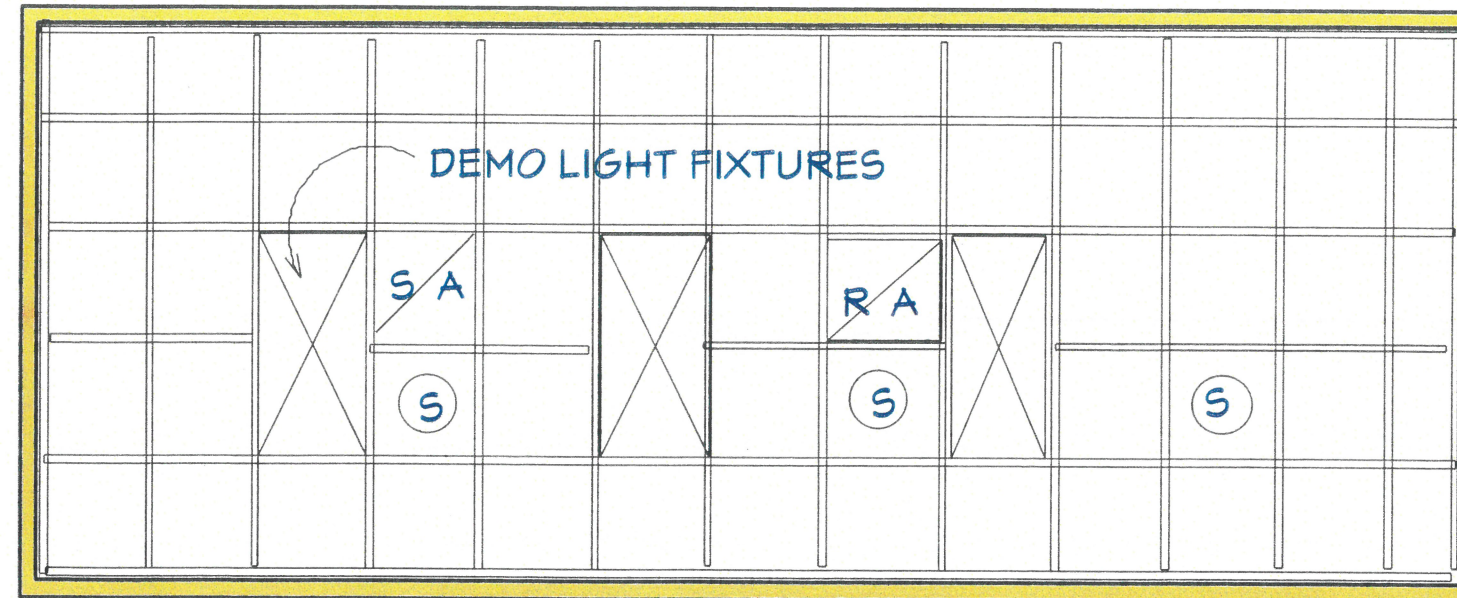

EXISTING SUSPENDED CEILING

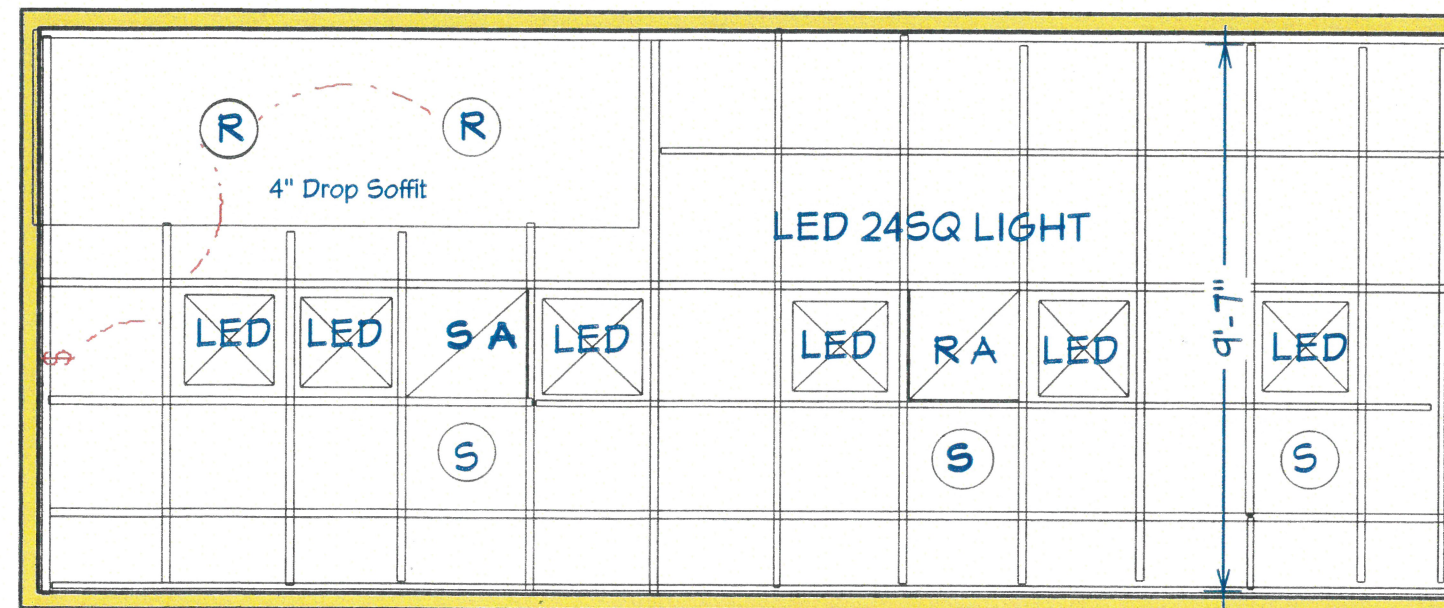

REFLECTED CEILING PLAN

**JIM WOODWORTH**  
**architect**  
 1055 Woodfield Estates Dr.  
 Town & Country, MO 63017  
 314-277-7552  
 FAX 314-576-3503  
 jpwoodworth@att.net

**WOMEN RESTROOM**  
**REFLECTED CEILING PLANS**  
**BALLWIN EVENT CENTER**  
 333 Holloway Road  
 Ballwin, MO 63011



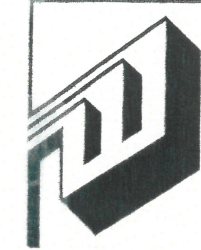

**JIM WOODWORTH**  
**architect**  
 1055 Woodfield Estates Dr.  
 Town & Country, MO 63017  
 314-277-7552  
 FAX 314-576-3503  
 jpwoodworth@att.net

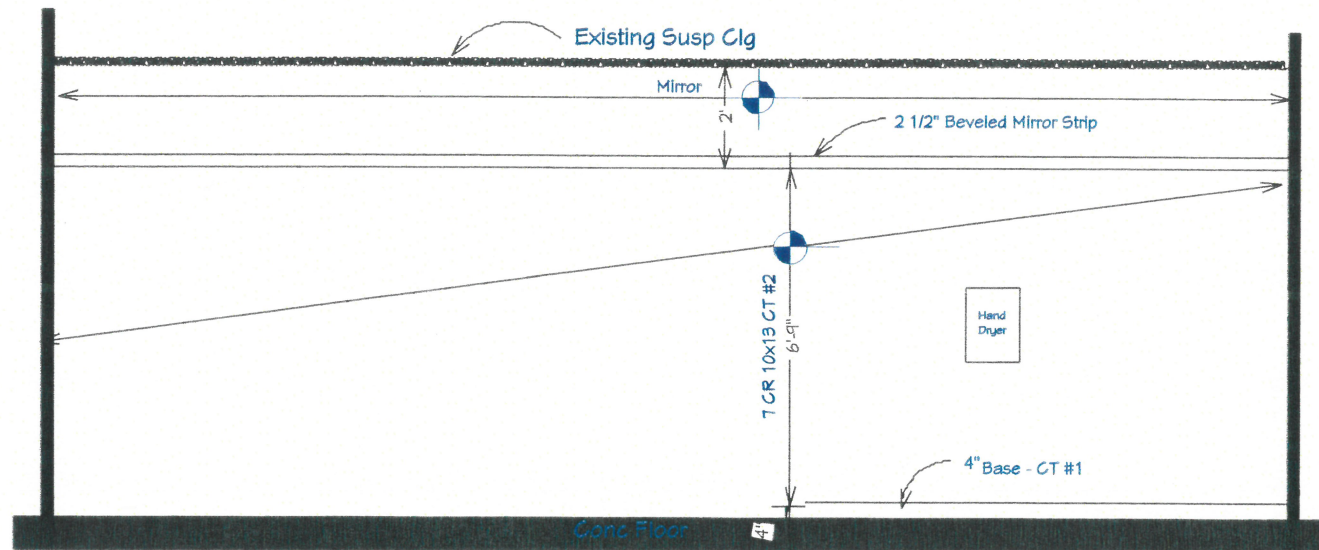

**Elevation 2**

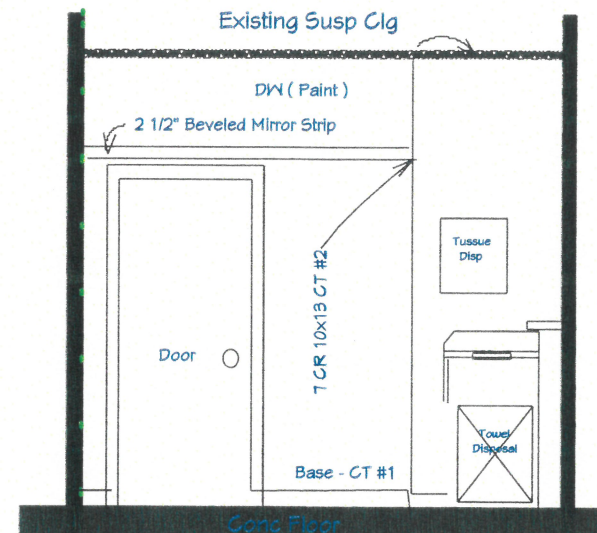

**Elevation 4**

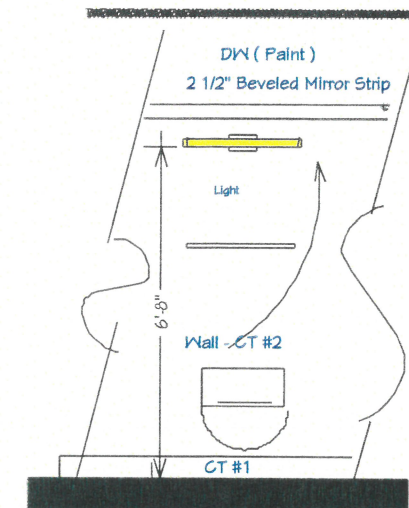

**TYPICAL WALL BEHIND TOILET**

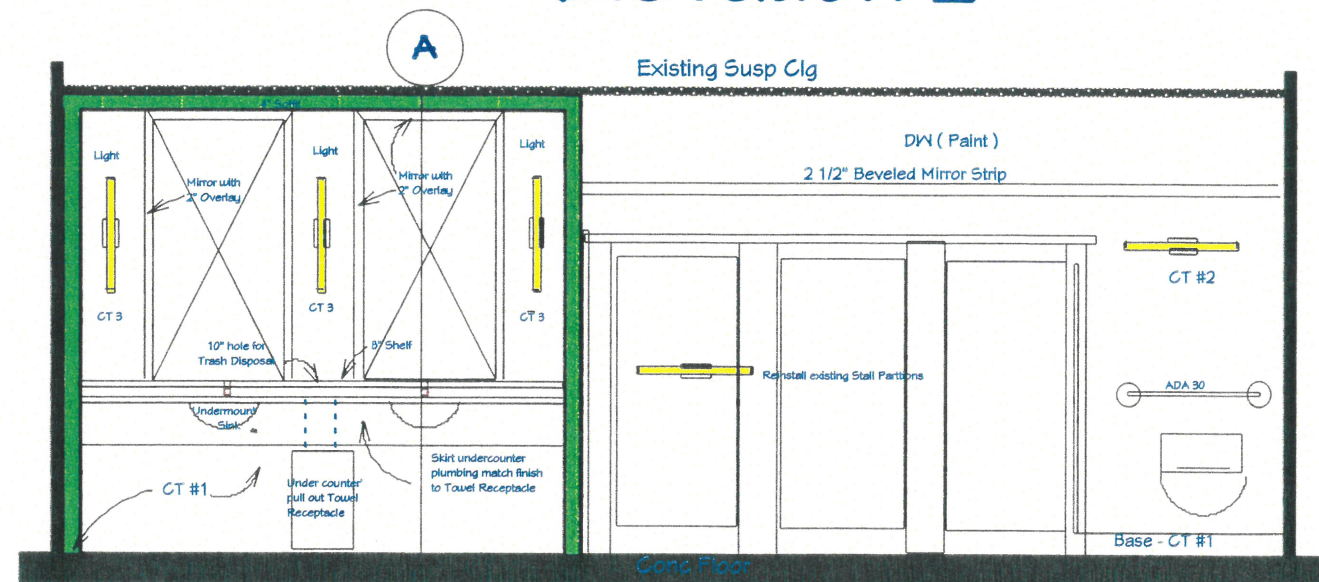

**Elevation 1**

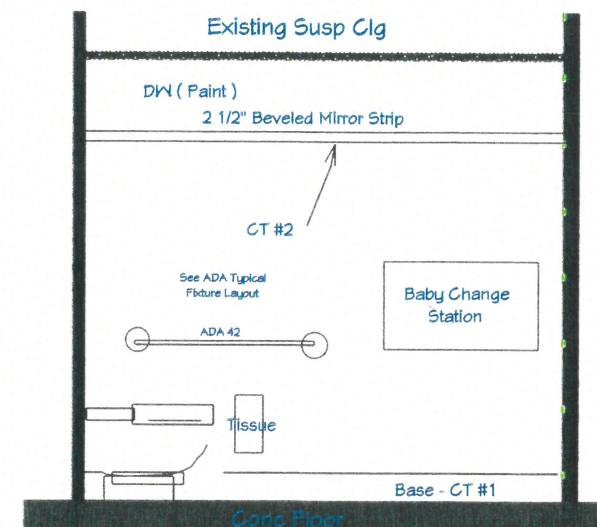

**Elevation 3**

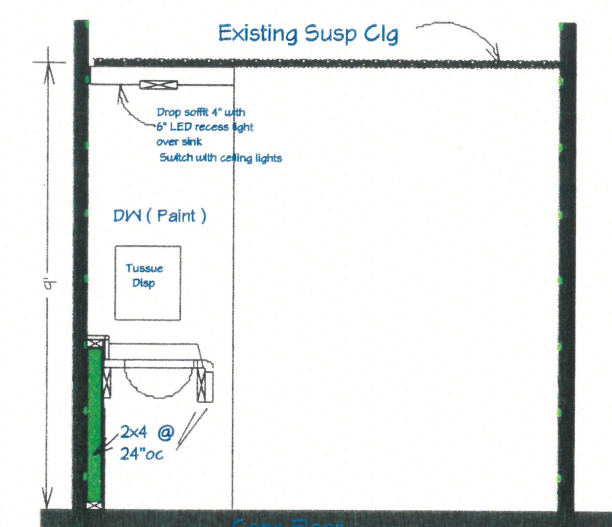

**Section A**

**WOMEN RESTROOM**  
**WALL ELEVATIONS**  
**BALLWIN EVENT CENTER**  
 333 Holloway Road  
 Ballwin, MO 63011



March 10, 2026

# GENERAL NOTES

## APPLICABLE BUILDING CODES

City of Ballwin  
International Building Code 2021

## SCOPE OF WORK

This scope of work is limited to the Ballwin Event Center  
REMODELING of the Men's and Women's Restrooms  
NO CHANGE HVAC, PLUMBING & FIRE SPRINKLERS

## FINISHES

### 1 GYPSUM BOARD

Walls 5/8" water resistant drywall  
Walls 2x4 wood studs (to match existing walls)

### 2 PAINTING

One prime coat and two finish coats on all drywall and wood trim.

### 3 DEMO, SALAVGE & MAINTENANCE

Remove the existing FLOOR and WALL  
salavage for reuse all metal Toilet partitions

## MECHANICAL

Restrain all mechanical equipment seismic forces.

Insulate hot and cold water lines above grade in non heated areas.

Materials shall be as follows:

- a) Water piping shall be copper or PEX.
- b) Vent piping PVC.

GFI receptacles above counter tops within 6' of water sources and in unfinished storage areas.

See Plans

Clean and check existing ceiling exhaust fan, replace if required.

### VERIFY EXISTING SYSTEM COMPLIES WITH CODE

Install emergency lights and EXIT signs internally illuminated to 5 F.C. as shown on plans. EXIT sign letters shall have 6" letters with 3/4" strokes, exit signs shall have a 90 minute battery backup power source. Emergency lights shall provide 1 F.C. over the egress path.

### VERIFY EXISTING SYSTEM COMPLIES WITH CODE

Smoke detectors shall be interconnected, AC powered, UL approved and installed per NFPA 72-99.

### VERIFY EXISTING SYSTEM COMPLIES WITH CODE

Carbon monoxide detectors to comply with UL 2034-2008.

MEN	WOMEN
1	1
1	1
2	2
1 @ 42"	1 @ 42"
1 @ 30"	1 @ 30"
4	4
4	4
0	1
0	1
1	1
4	4
4	4
4	4
4	4
2	0

## RESTROOM FIXTURES

NOTE: Fixture Selections are based on BOBRICK for their style and quality.

Other Manufacturers with products meeting these standards are acceptable

### RESTROOM FIXTURE CLEARANCES

- 1 All fixtures ADA compliant
- 2 Distance between - sinks & toilet 21"/sink and center line toilet 15", walls and shower 24"

### RESTROOM FIXTURE SELECTIONS

#### HAND DRYER

Surface mount - Bobrick B-7188 Terra Dry

#### TOWEL & WASTE RECEPTACLE

Combo Recessed 27"x56: Receptacle - Bobrick B-43944

Combo Recessed 10"x28" Receptacle - Bobrick B-4369

Combo Tissue (dbl roll) / Seat Cover Dispenser-Surface Mount Bobrick B-30919, Recess B-3091

#### GRAB BARS

#### TOILET TISSUE DISPENSER

Surface Mount - Bobrick B-4288 Multi Roll & Utility Shelf

#### SOAP DISPENSER

Lavatory Surface Mount - Auto Foam Dispenser - Bobrick B-8263

Wall Mount - Automatic Foam Dispenser - Bobrick B-2013

#### NAPKIN & TAMPON DISPENSERS

Wall Mount - Sanitary Napkin Dispenser - Gamco ND-1

Recess Mount - Sanitary Napkin Disposal SS - Bobrick 35303

Wall Mount - Combo Tissue (dbl roll) / Seat Cover Dispenser-Surface Mount Bobrick B-30919, Recess B-3091

#### BABY CHANGING STATION

Recess Wall Moun - Kola Care KB310-SSRE

#### PARTITIONS - TOILET STALLS & URINALS

Toilet Stall Partitions -Bobrick - ADA compliant , steel baked powder coated steel baked (Black Color).

Urinal Partitions -Bobrick - Wall mount , steel baked powder coated steel baked (Black Color).

#### TOILETS & URINALS

American Standard Maderia Auto Touchless Flush Valve, elongated bowl, floor mount Model 3043 528.020

American Standard Atwell Millennium-Ever Clean System, Wall Mount, Touchless Flush Valve, Model 3551511-02

Urinal - Wall Mount - XPODIRRS Commercial Induction Urinal, Auto Splash Proof Flushing - White

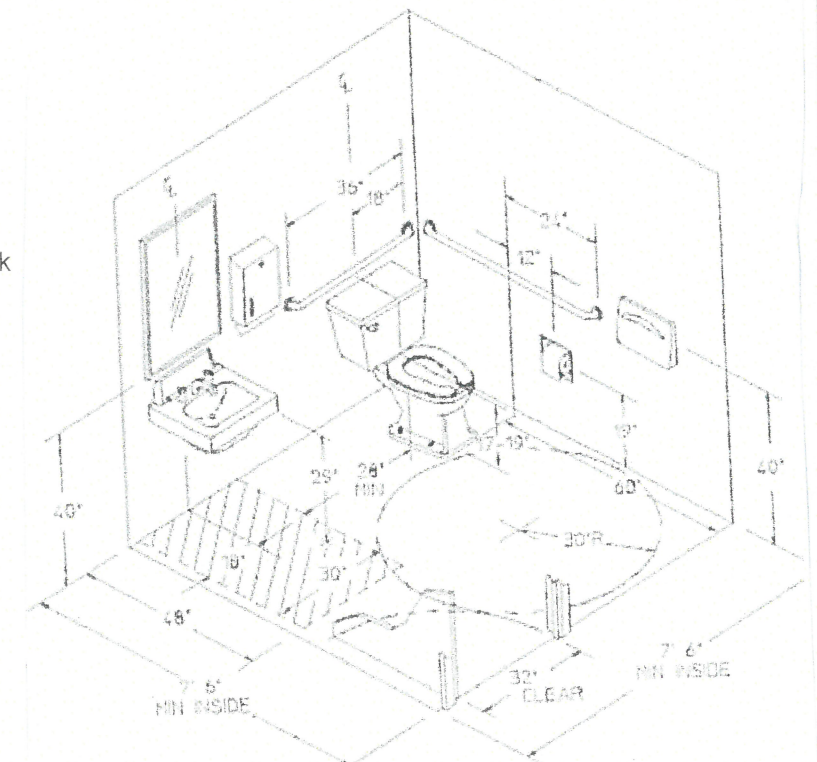

Saved from [partitionsandstalls.com](http://partitionsandstalls.com)

## ADA Bathroom Layout | Commercial Restroom...

**GENERAL NOTES & FIXTURE SELECTIONS**  
**BALLWIN EVENT CENTER**  
333 Holloway Road  
Ballwin, MO 63011

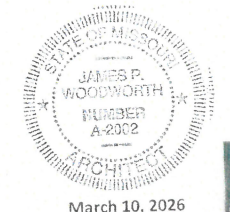

March 10, 2026